

Technical data

Max working height	16.0 m
Max height basket floor	14.0 m
Moving height	9.80 m
Max outreach (load 80 kg)	8.50 m
Max outreach (load 230 kg)	6.70 m
Rotation angle	+/-110°
Basket size	1.40 x 0.70 m
Basket rotation angle	+/- 70°
Max basket capacity	230 kg
Length in stowed position (with detached basket)	5,10 (4,40)
m Min width in stowed position	1,35 m
Max working width	2.45 m
Min height in stowed position	1.99 m
Longitudinal leveling	+/- 15°
Lateral leveling	+/- 15°Max
gradeability	25°Max side
gradeability	25°Drive
speed (fast)	2.00 km/h
Security speed	0.40 km/h

Weights

Traffic load	315 kN/m2
Total weight	3910 kg

Power

3TNM68 -AS Yanmar engine (diesel)	14 kW – 19,2 Hp
	@3600rpm

Extras - On Demand

Non-marking tracks	-
Electric pump 220V-2,2KW / 50Hz	- Weight +30kg
Radio remote control	-
Arctic lubricant for cold climate	-
Ultrasonic Anti-collision System	

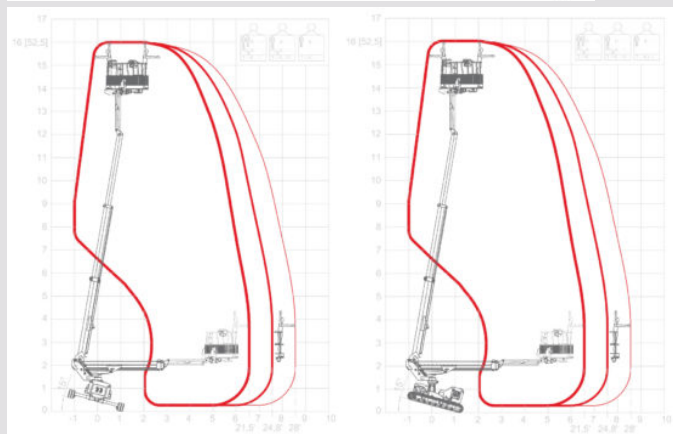
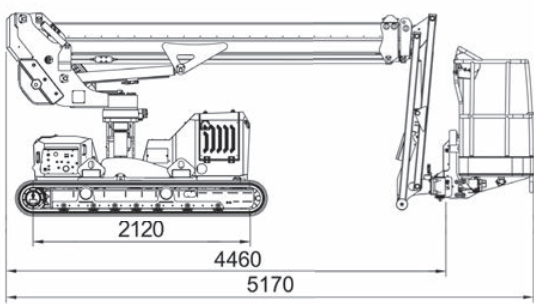

JIBBI 1670 EVO

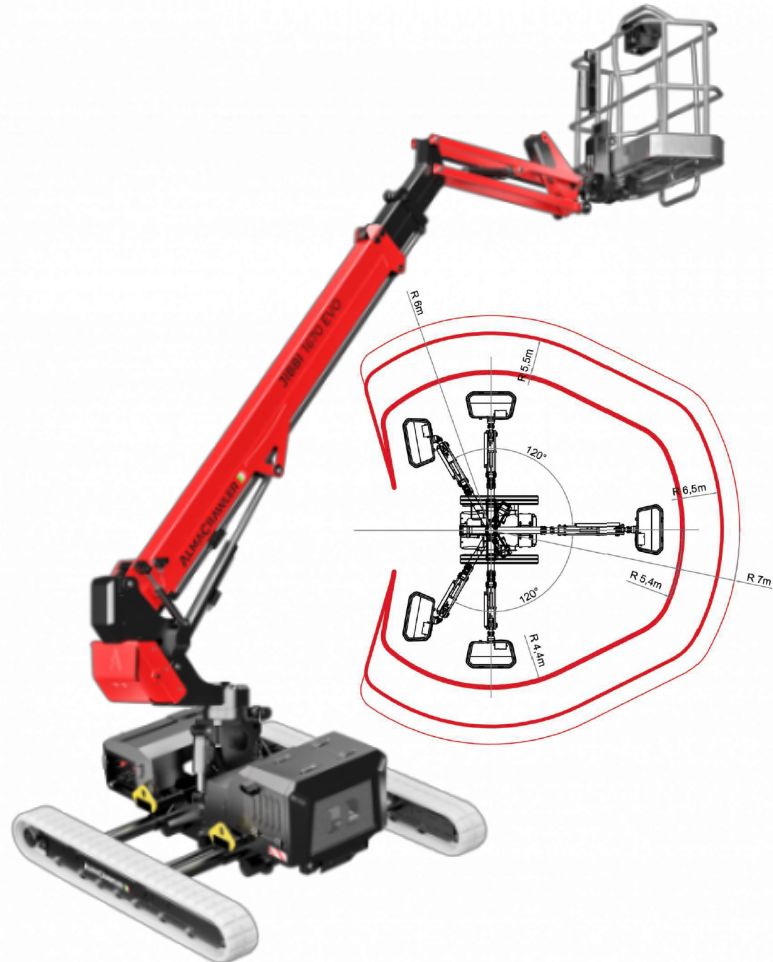

Other Features:

- 240° Slewing ring rotation
- Basket rotation kit +/- 70°
- Integrated Drive System (using single joystick)
- automatic and dynamic leveling.
- Compact Dimensions.
- Removable basket

